



## Gear Driven 20 Qt. Commercial Mixer

**Models:** MX20

Shifting gears while this unit is running will void warranty.

11/2010

***Please read and keep these instructions. Indoor use only.***

## Index

Parts Overview .....	3
Standard Accessories.....	4
Operation Instructions .....	4
Mixer Capacity Chart .....	5
Troubleshooting And Specifications.....	6
Figure 1 Transmission Case .....	7
Figure 2 Planetary Shaft Assembly .....	8
Figure 3 Transmission Shaft Assembly .....	9
Figure 4 Worm Gear Assembly Shaft .....	10
Figure 5 Motor Unit .....	11
Figure 6 Shift Mechanism.....	12
Figure 7 Stand & Bowl Lift Unit .....	13
Figure 8 Lifter Unit .....	14
Figure 8 Planetary Assembly .....	15
Electric Diagram .....	16
Warranty Information .....	17

## Parts Overview

ITEM	DESCRIPTION
1	Cover
2	Rear Cover
3	Safety Guard
4	Mixing Device
5	Bowl Lift Wheel
6	Bowl

**Notes:**

- Do not hose down mixer.
- Do not operate the mixer with wet hands.
- Unplug mixer from electrical supply prior to any maintenance or repairs.

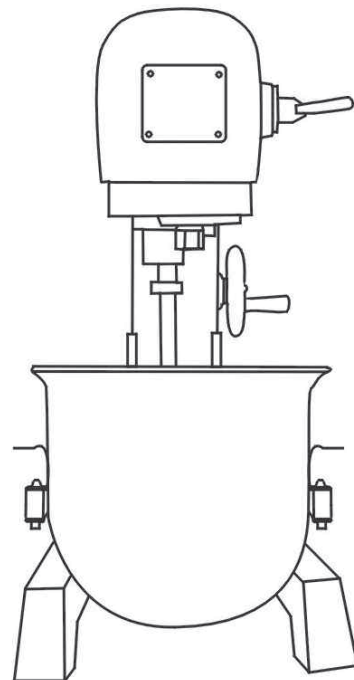
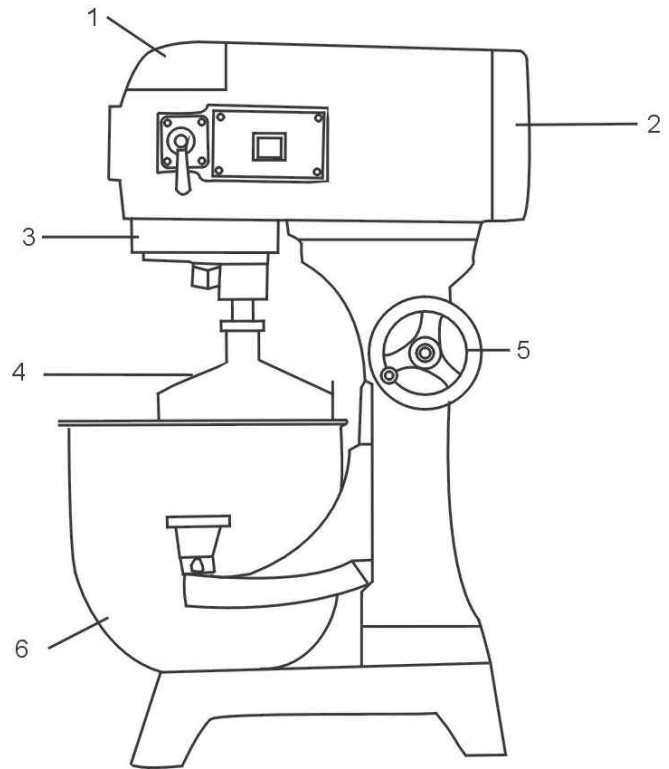

## Standard Accessories

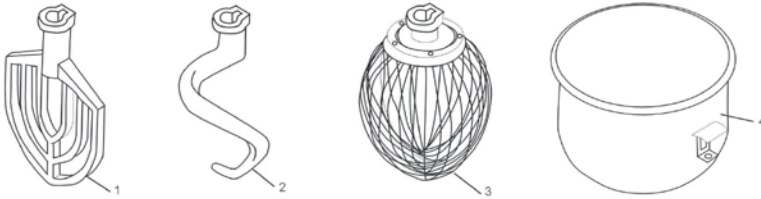

Item	Description	Qty
1	Spatula	1
2	Dough Hook	1
3	Wisk	1
4	Bowl	1

### NOTES:

- Any agitator is easily installed by simply raising it onto the mixing axle, and then rotating it clockwise on the shaft until it locks into place. To remove, raise the agitator on the shaft until it clears the lock and then rotate counter-clockwise and lower.
- All of the accessories are precisely fitted to the bowl, have rounded corners, and are easily removable for cleaning.

## Operation Instructions



Please ensure that your power supply matches your machine

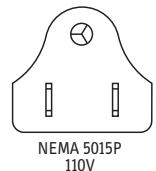

**For changing the speed:** Please stop machine first before changing speed in order to avoid damage to the gear box.

**Mixing:** Always use the correct attachment for the job.



**A. Wisk:** Suitable for mixing liquids and soft ingredients, can work in all speeds. Do not run for more than 15 minutes.



**B. Spatula:** Suitable for mixing dry ingredients, can work in low & medium speeds only. Do not use in high speed. Do not run for more than 15 minutes.



**C. Dough Hook:** Suitable for mixing dough, can work in low & medium speeds only. Do not use in high speed, do not run for more than 20 minutes. Absorption ratio must be more than 50%. Refer to mixer capacity chart.

## Mixer Capacity Chart

Product	Agitator and Speed	Maximum Bowl Capacity 20 qt
Bread and Roll Dough -60 % AR	Dough Hook - 1st only	25 lbs.
Heavy Bread Dough -55% AR	Dough Hook - 1st only	15 lbs.
Pizza Dough, Thin -40% AR	Dough Hook - 1st only	9 lbs.
Pizza Dough, Medium -50% AR	Dough Hook - 1st only	10 lbs.
Pizza Dough, Thick -60% AR	Dough Hook - 1st only	10 lbs.
Raised Donut Dough -65% AR	Dough Hook - 1st and 2nd	20 lbs.
Mashed Potatoes	Flat Beater	15 lbs.
Waffle or Hot Cake Batter	Flat Beater	8 qt.
Egg Whites	Wire Whisk	1 qt.
Whipped Cream	Wire Whisk	4 qt
Cake Batter	Flat Beater	20 lbs.

When mixing dough ( pizza, bread or bagels), check your "AR" absorption ratio - water weight divided by flour weight. Above capacities based on 12% flour moisture at 70°F water temperature. If high gluten flour is used, reduce above dough batch size by 10%.

**Example:** If recipe calls for 5 lbs. of water and 10 lbs. of flour, then  $5 \div 10 = 0.50 \times 100 = 50 \%AR$ .

- 2nd Speed should never be used on mixtures with less than 50% AR.
- Do not use attachments on hub while mixing.

When calculating the correct size mixer for your application, here are some helpful weights & measures:

- **8.3 lbs. = 1 gallon of water – 2.08 lbs. = 1 Quart.**

## Troubleshooting

Trouble	Possible Causes	Solution
The axles can't work when operating the machine	Poor contact of the electrical equipment	Check the Plug
The mixing bowl is out of position	Moving direction is not correct	Change
Leaks oil	Sealing washer is damaged	Change
Difficult to move the bowl up and down	Slideway is rusted	Clean the slideway and lubricate
The motor is overheated and speed is down	The voltage is not enough, or incorrect speed	Check the voltage or use lower speed
Noise and overheating	Poor lubrication	Add or change lubrication
Mixer touches bowl	The mixing device or bowl deformed	Repair or change the bowl or mixing device

## TRANSMISSION CASE

FIGURE 1

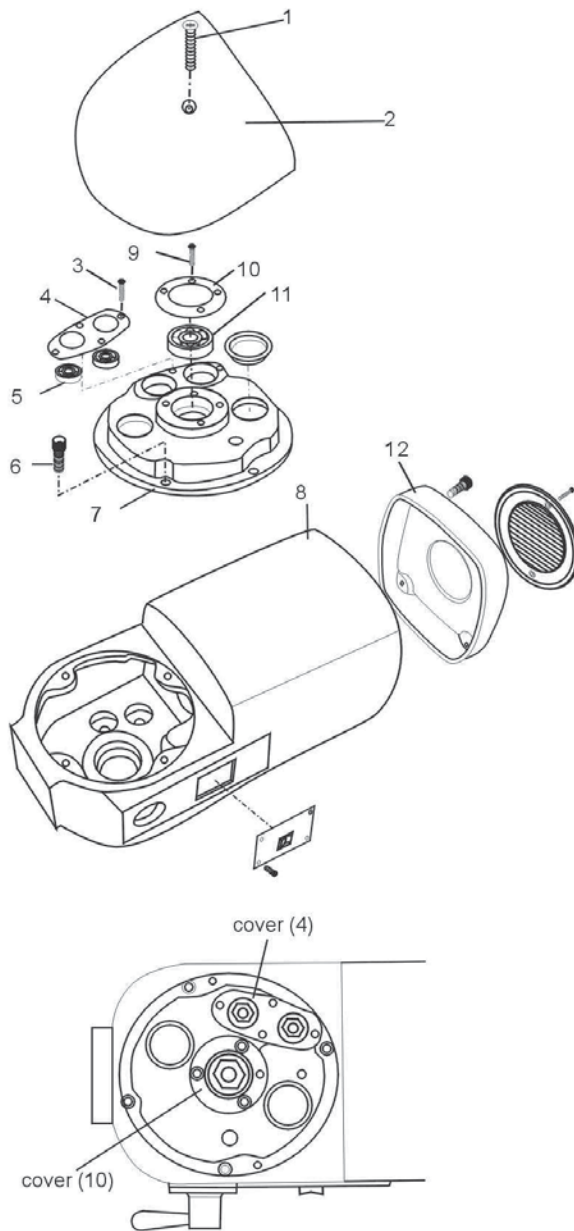

ITEM	DESCRIPTION	QTY
1	Screw M6*45	1
2	Cover	1
3	Screw M5*8	4
4	Cover	1
5	Bearing 6201	2
6	Screw M6*25	4
7	End Cover	1
8	Body	1
9	Screw M5*8	3
10	Cover	1
11	Bearing 6003	1
12	Rear cover	1

**NOTES:**

- The factory has provided superior lubricant for several years of use. If the mixer is repaired please ensure that the service technician replaces any lubricant lost or removed.

- Please lubricate bearings before refitting bearing covers.

## PLANETARY SHAFT ASSEMBLY

FIGURE 2

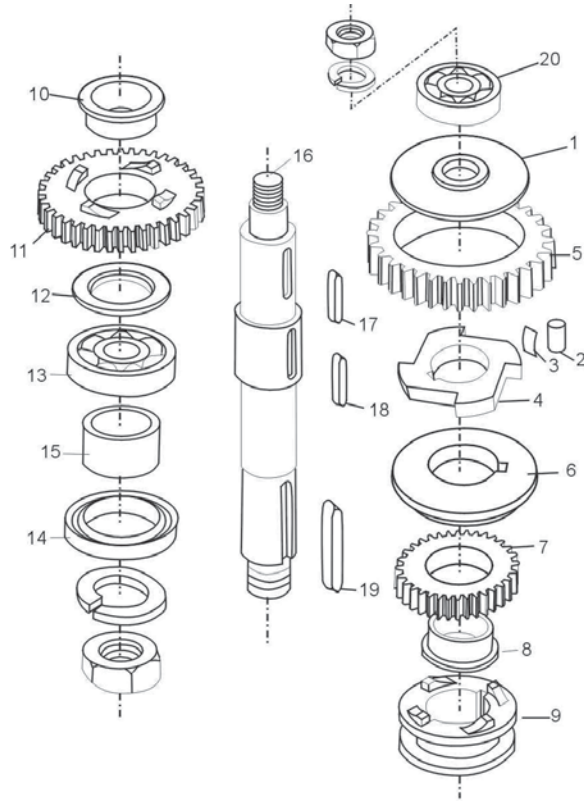

ITEM	DESCRIPTION	QTY
1	Baffle	1
2	Roller	4
3	Spring	8
4	Engager	1
5	Gear Ring	1
6	Dividing Ring	1
7	Joint Gear I	1
8	Bearing Ring	1
9	Joint	1
10	Bearing Ring	1
11	Joint Gear I	1
12	Ring	1
13	Bearing 6205	1
14	Oil Seal Pd30*45*10	1
15	Sleeve	1
16	Axle	1
17	Key 6*14	1
18	Key 5*35	2
19	Key 6*30	1
20	Bearing	1

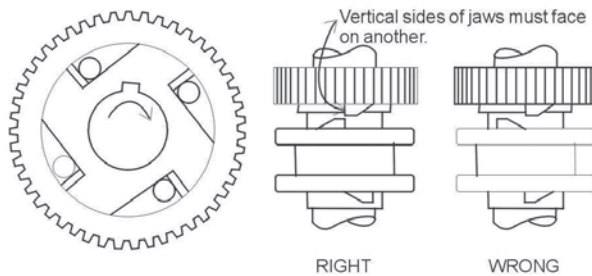

FIGURE 2-1

FIGURE 2-2

**NOTES:**

- Be sure to install correct position (see Figure 2-1) and lubricate all of the pins in the sleevedrive when reassembling.
- Joint (9) must always be raised and lowered smoothly. Be sure joint sleeve as shown in Figure 2-2
- Check oil seal (14), if serious oil leaks from drip cup.

## TRANSMISSION SHAFT

FIGURE 3

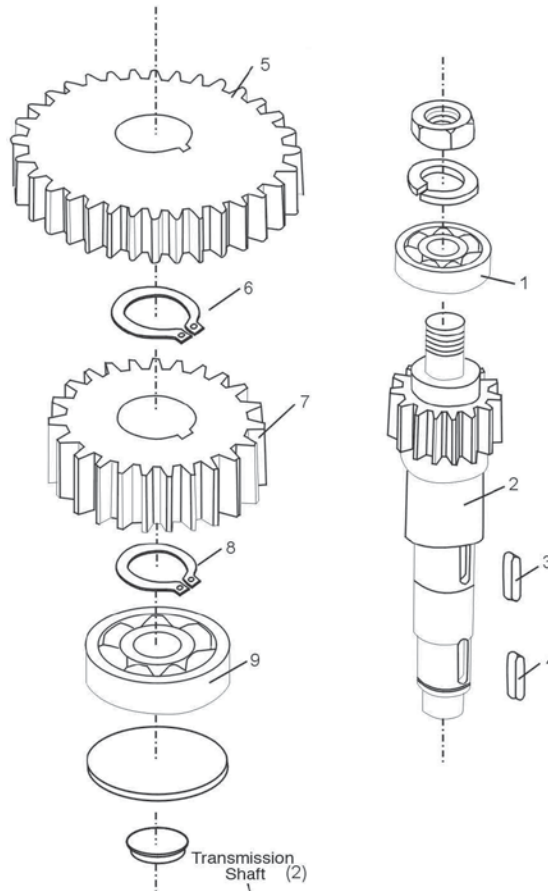

ITEM	DESCRIPTION	QTY
1	Bearing	1
2	Transmission Axle	1
3	Key 5*11	1
4	Key 5*11	1
5	Gear	1
6	Stop Ring	1
7	Gear	1
8	Stop Ring	1
9	Bearing 6201	1

**NOTES:**

- At the center in the shaft unit. To the above gear is the gear shaft and gear shaft I (see figure 3-1)
- C-type stop ring (6/8) has to be fixed when reassembling.
- Be sure that the keys are inserted for each gear.

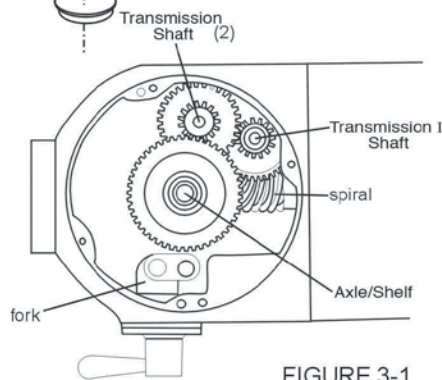
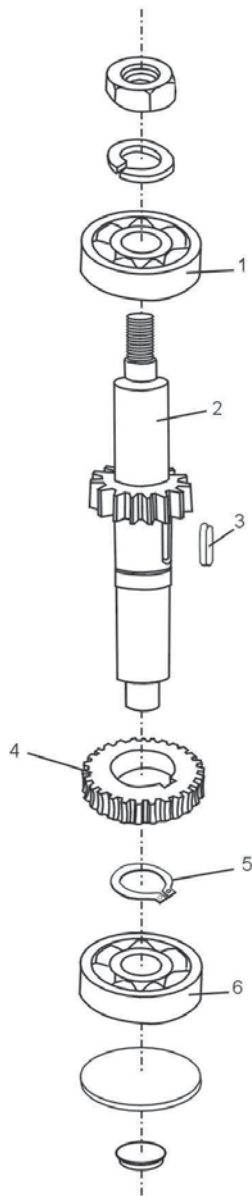

FIGURE 3-1

## WORM GEAR SHAFT ASSEMBLY

FIGURE 4



ITEM	DESCRIPTION	QTY
1	Bearing 6201	1
2	Gear Axle	1
3	Key 5*14	1
4	Gear	1
5	Stop Ring	1
6	Bearing 6201	4

**NOTES:**

- C-Type stop ring (5) has to be fixed when reassembling.

## MOTOR UNIT

FIGURE 5

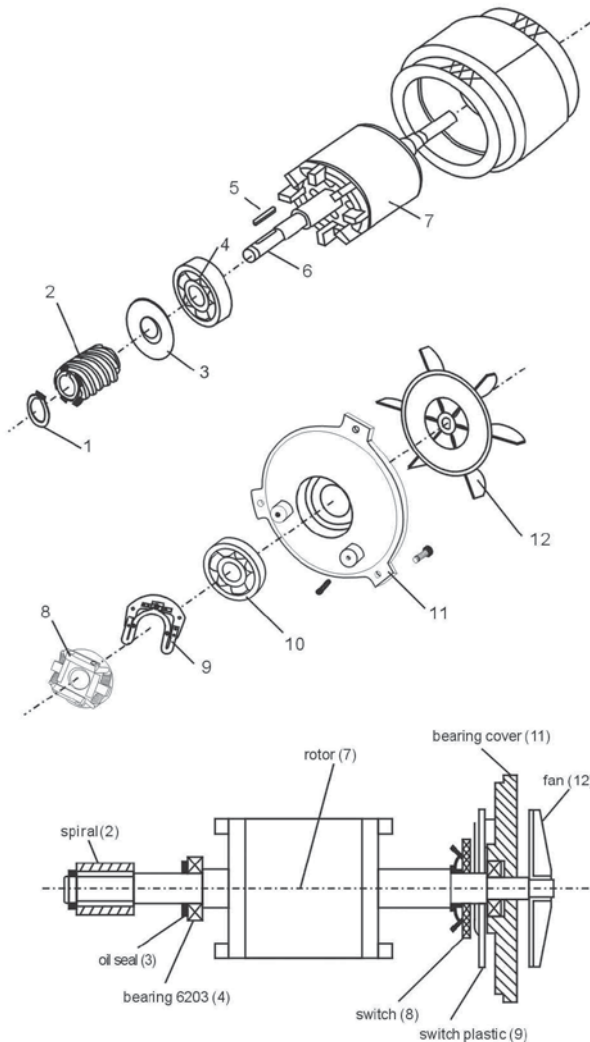

FIGURE 5-1

ITEM	DESCRIPTION	QTY
1	Stop Ring	1
2	Worm Gear	1
3	Oil Seal	1
4	Bearing 6203	1
5	Key 4*22	1
6	Axle	1
7	Rotor	1
8	Governor	1
9	Governor Plate	1
10	Bearing 6203	1
11	Bearing Cover	1
12	Fan	1

**NOTES:**

- If the motor does not work, first verify the power source and connection. Next, check for damaged or faulty wiring or connections inside the mixer. A faulty motor may be the result of incorrect voltage, broken wires, a defective centrifugal governor. Motor damage may also be caused by bowl over load during mixing.

- Motor set includes motor axle (6), rotor (7) and stator.

- Figure 5-1 is component system diagrams of motor.

## SHIFTING MECHANISM

FIGURE 6

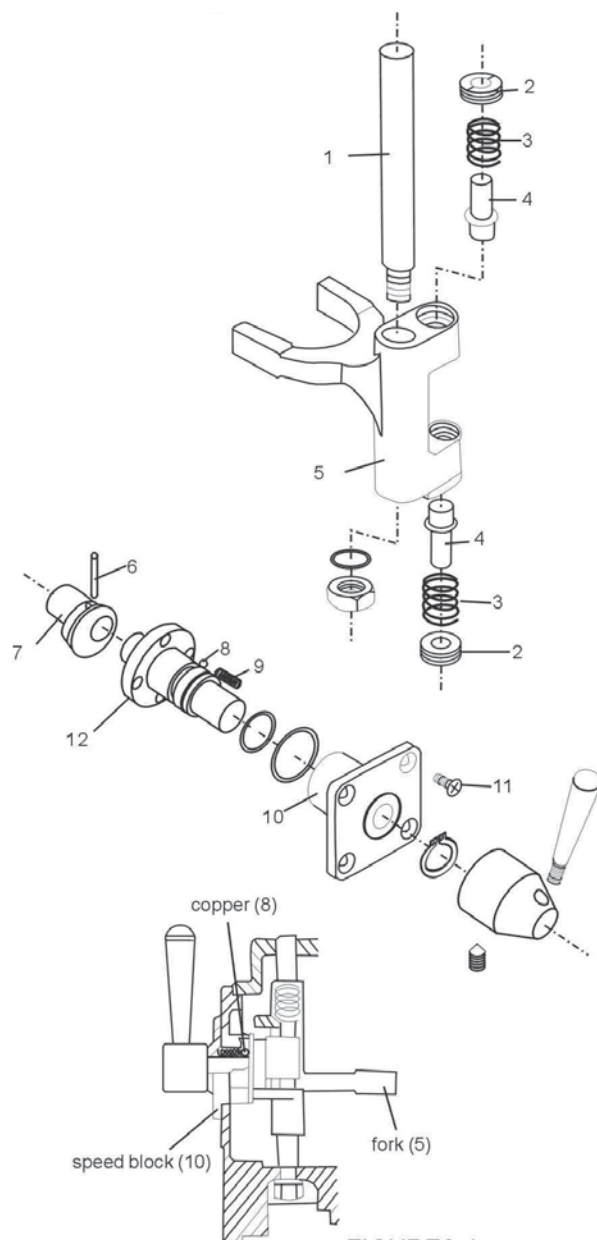

FIGURE6-1

ITEM	DESCRIPTION	QTY
1	Axle	1
2	Nut	1
3	Spring	1
4	Shaft	1
5	Fork	1
6	Pin 3*20	1
7	Eccentricity Knot	1
8	Steel Ball	3
9	Speed Spring	3
10	Speed Block	1
11	Screw M5*10	1
12	Shaft	1

### NOTES:

- The speed selector / shifting mechanism is designed for simplicity and reliability. It features three mixing speeds.

- Apply sealant to the shift selector assembly when installing.

- Speed selection is made by aligning the pointer of the shift handle to the required action.

i.e. Whisk for eggs & cream etc,

Paddle for batter

Hook for dough

**Important: Stop the mixer before changing speed.**

## STAND & BOWL LIFT UNIT

FIGURE 7

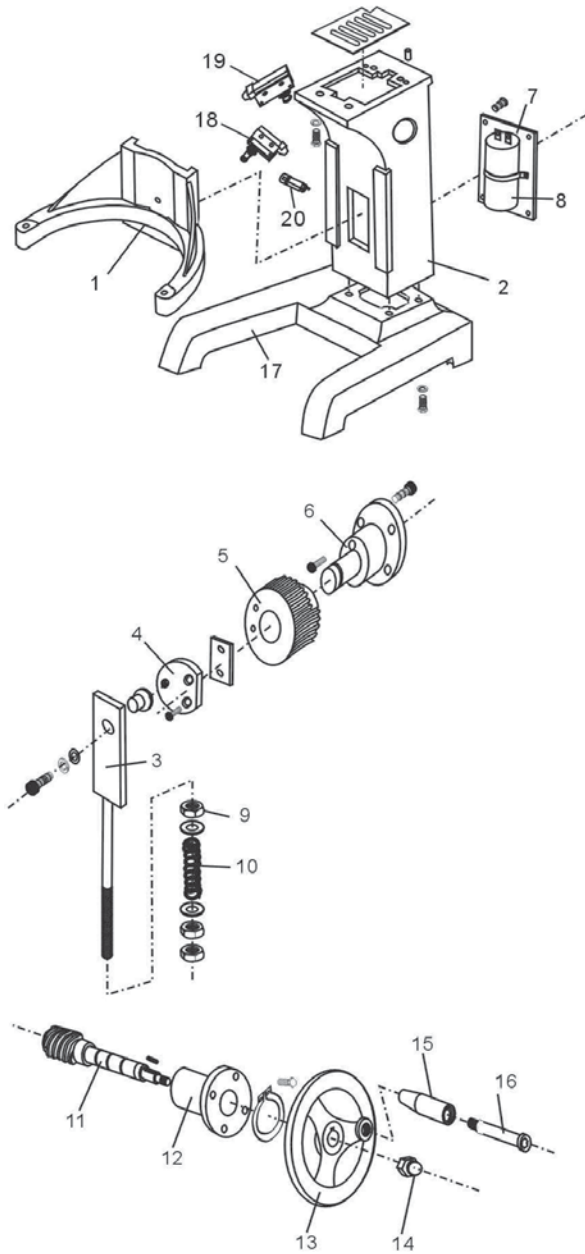

ITEM	DESCRIPTION	QTY
1	Bowl Support	1
2	Columns	1
3	Slide	1
4	Plate	1
5	Gear	1
6	Support Seat	1
7	Capacitor Board	1
8	Capacitor 200uF	1
9	Nut M10	3
10	Spring	1
11	Spiral	1
12	Bowl Lift Support	1
13	Handwheel	1
14	Nut M10	1
15	Handle	1
16	Handle Screw	1
17	Machine Seat	1
18	Limit Switch of Safety Guard	1
19	Fluctuate Safety Switch	1
20	Overload Protection Switch	1
21	AC Contact Device	1
22	AC Contact Device Box	1

## BOWL LIFT UNIT

FIGURE 8

ITEM	DESCRIPTION	QTY
1	Lifting Bar	1
2	Cotton Pin 3*30	1
3	NutM10	3
4	Flat Washer	2
5	Compression Spring	1
6	Little Knot	1
7	Lifting Handle Bracket	1
8	Flat Washer	1
9	Flange Knot	1
10	Screw M6*25	1
11	Key 5*20	1
12	Bowl Lift Handle	1

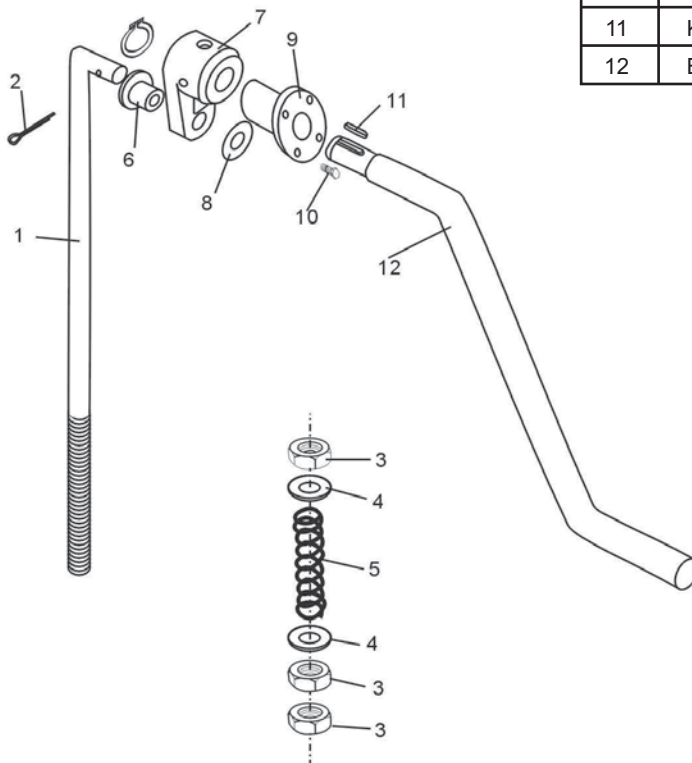

## PLANETARY ASSEMBLY

FIGURE 9

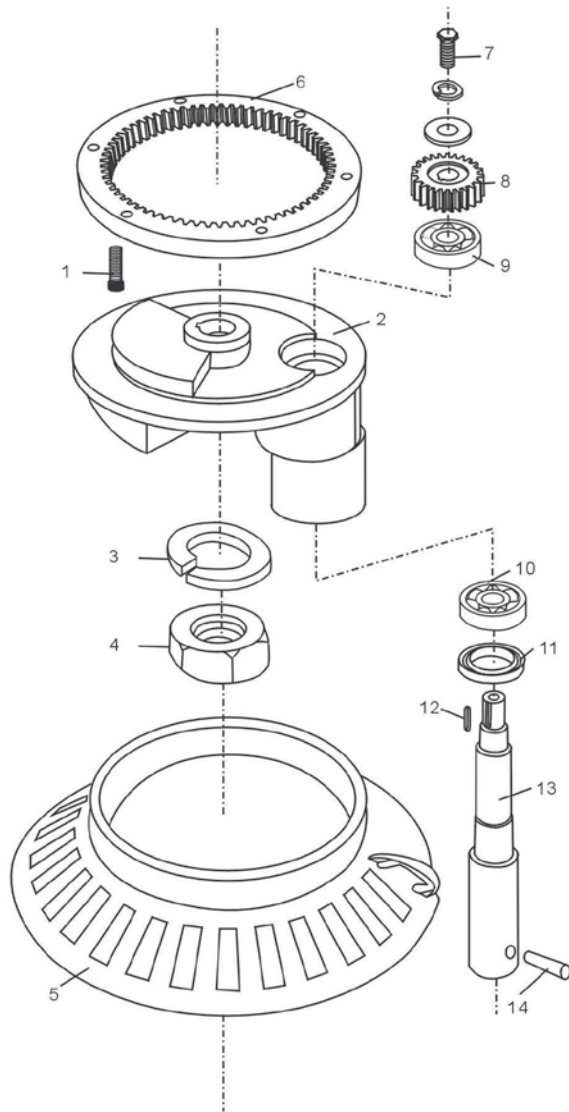

ITEM	DESCRIPTION	QTY
1	Screw M6*45	6
2	Turning Plate	1
3	Ring	1
4	Nut M20*1.5	1
5	Safety Guard	1
6	Inner Gear	1
7	Screw M8*15	1
8	Planetary Gear	1
9	Bearing 6203	1
10	Bearing 6204	1
11	Oil SealPd25*50*10	1
12	Key 5*18	1
13	Mixing Axle	1
14	Pin	1



## Limited Warranty

All equipment, which is sold under Avantco trademark and used for commercial purpose is warranted against defects in materials and workmanship. The warranty runs for one year from the date of original installation and is for the benefit of the original purchaser only. All other Warranties, Expressed or Implied, Statutory or Otherwise, including Without Limitation any implied Warranty of Merchantability or Fitness for Purposes are excluded. The Seller shall in no event be liable for direct, indirect or consequential damages in connection with Avantco commercial products.

This warranty is not effective if damage occurs because of accident, carelessness, improper installation, lack of proper set – up, supervision when required or if the equipment is installed or operated in any manner contrary to the installation and operating instructions. In these cases, repairs will be made at a reasonable cost. Work performed by unauthorized personnel or unauthorized service agencies voids this Warranty.

Items not covered under warranty:

Changing Gears on the Mixers while Unit is Running and Overloading as Determined by an Approved Certified Technician.